

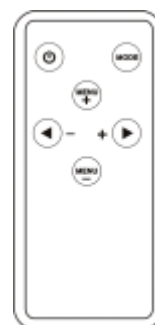

RM-9020

Roof Mount LCD Monitor

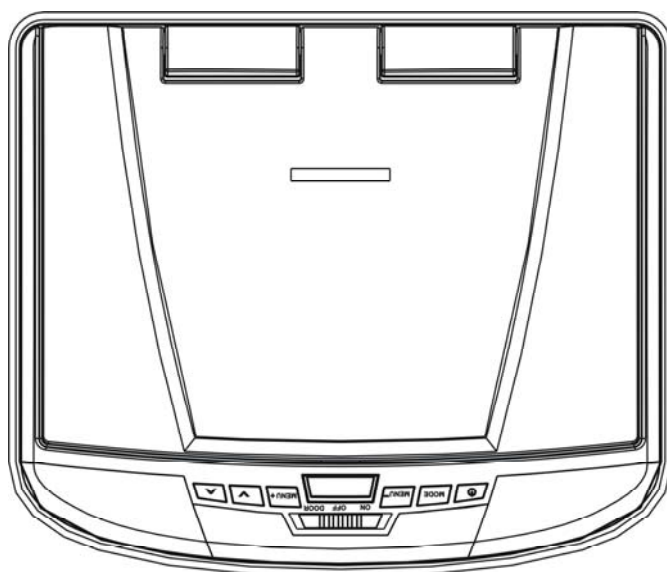

Operating Manual

CONTENTS

Welcome	1
Introduction	1
Safety Precautions	2
Package Contents	4
LCD Panel Adjustment	5
Button Functions	6
Remote Control	8
Battery Replacement.....	8
Installation Instructions.....	9
Troubleshooting	10
Picture Adjustment	11
Maintenance	12
Specifications	12
Wiring / Connections.....	13
Installation Steps	16

1. WELCOME

Thank you for buying the Roof Mount LCD Monitor. Please read this manual carefully before using the Roof Mount LCD Monitor in order to get the most out of all the features and functions. Keep this manual safely , as it can be a valuable tool in helping you to understand all the Monitor's capabilities.

2. INTRODUCTION

This is a Roof Mount 9.2" TFT-LCD Color Monitor that can be used as a stand-alone display, or can be integrated into a mobile multimedia system. The unit has the following features:

- 9.2" TFT-LCD color monitor (16:9)
- Roof Mount Application
- Auto Switch NTSC/PAL
- Pixel (dots):2400(W) x480(H)
- Adjustable Color/Contrast/Brightness/Tint
- Manual Viewing Angle Adjustment
Vertical Adjustable: up/down<180⁰
- White LED Dome Light
- Automotive Startup Protection
- Automotive Battery Exhausted and Over Voltage Protection
- IR Remote Control
- On Screen Display (OSD)
- Size: 235mm(W) x265mm(H) x32.5mm(D)
- 2xAV Input
- 1xAV Output
- IR Transmitter









3. SAFETY PRECAUTIONS

- The unit is designed for using in DC12V, negative ground battery.
- Do not operate the unit in any way other than described within this manual. Failure to follow the instructions within the manual will invalidate your warranty.
- SAFETY FIRST! Do not install the display where it may (i) obstruct the driver's vision, (ii) impair the performance of any of the vehicle's operating systems or safety features, including airbags, or (iii) impair the driver's ability to safely operate the vehicle.
- When using the system, make sure you are firmly secured by your seat belt to ensure you do not accidentally hit your head on the screen during sudden braking or other incidents. If you are ever in an accident, injuries can be more severe if the seat belt is not properly buckled.
- Do not attempt to install or service your display by yourself. Installation or servicing of the display by persons without training and experience in electronic equipment and automotive accessories may be dangerous and could expose you to the risk of electric shock or other hazards.
- Be careful not to drain the car battery while using the unit with the car engine stopped. To avoid draining the battery, it is suggested that the vehicle engine always is running while using the unit.
- Do not disassemble or alter the unit in any way. Failure to do so can cause damage to the unit and invalid the warranty.
- Never clean the surface of the screen with chemical solvent or corrosive detergent, which may cause permanent damage to the TFT LCD screen.
- Avoid installing the unit wherever is under direct sunlight or near hot air vent. Please note that the normal working temperature of the unit is between -20°C to $+75^{\circ}\text{C}$. If the internal temperature of the vehicle is extremely high, a short cooling down period is necessary before operating the unit.
- If the temperature inside the car is very low and the monitor is used soon after switching on the heater, moisture may form on the panel of the unit. Turn off the unit immediately! Failure to do so may cause the internal components to short. Allow the unit to rest for about one hour to allow the condensation to disappear before continue operation.

- In extremely cold temperatures, the movement of the picture may be slow and the picture may be dark. It is not a malfunction. The unit will work normally once it reaches its operating temperature.
- Do not drop or hit the LCD panel with a hard object, as it may cause permanent damage to the LCD panel. Should LCD panel break, avoid touching glass and fluid. If do, please clean it with plenty of water and ask for medical attention immediately.
- Due to different car specifications, please kindly ensure that the display monitor is properly located and not obstructing the rear view mirror and air-conditioning vent.
- Use the supplied screws to fix the monitor Metal Mounting Plate.
- Kindly refer to authorized dealers if you have any questions.

Before installing this display system, please check with the conformity of your local traffic rules and regulations.

4. PACKAGE CONTENTS

Appearance	Parts Name	Quantity
	LCD Display	1
	IR Remote Control w/Battery	1
	Bus Cable	1
	Metal Mounting Plate	1
	ST4.2x16	4
	CM 4x8	4
	Adhesive foam	4
	User's Manual	1
	Rubber Spacer	1

Use only the contents of this package to install. Use of any accessories not provided with this monitor may result in damage to the display.

5.LCD PANEL ADJUSTMENT

- ① Open the LCD panel. Press Open Button to disengage the LCD panel. Pull the LCD panel outward till the desired viewing angle.

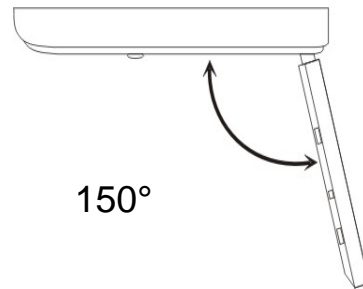
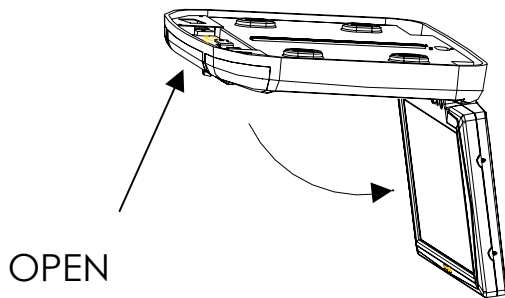

⚠ CAUTION:

- The LCD display opens to a maximum angle of 150° degrees. Opening it further than that may cause damages.

- ② Close the LCD panel.
Close manually until you hear the lock click.

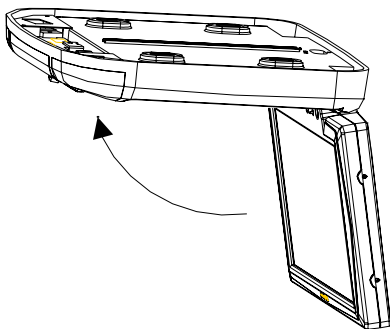

⚠ CAUTION:

- Make sure that cords and other items do not get caught in the panel when you close it.
- For your safety, be sure to close the LCD panel when not use it.

6. BUTTON FUNCTIONS

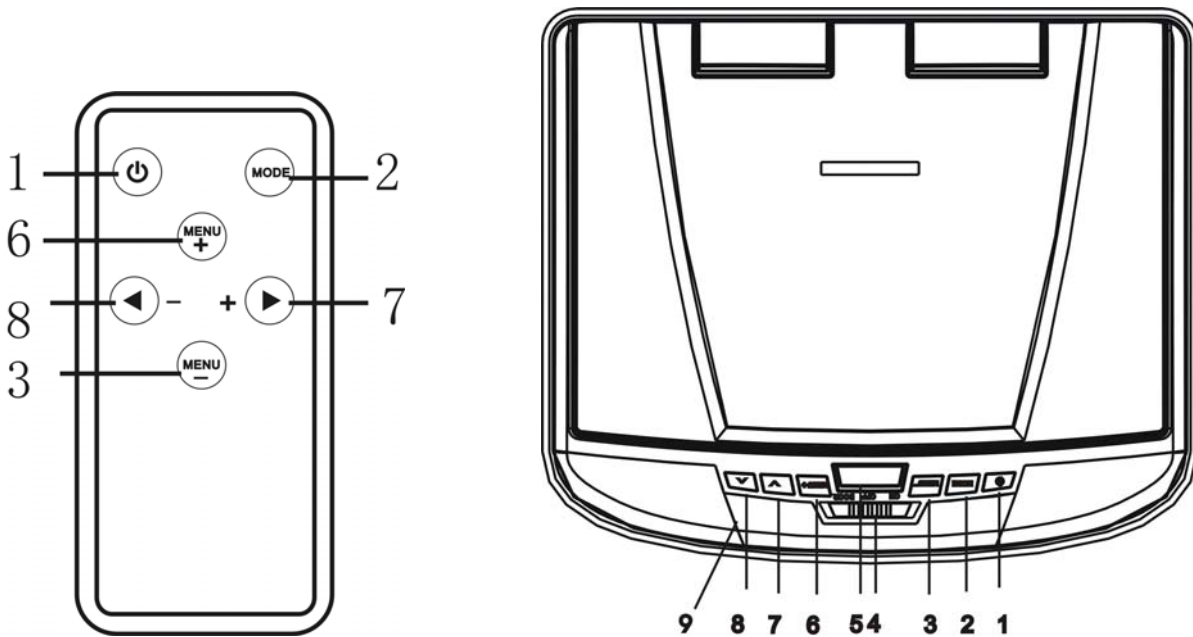

1. Power Button (⏻)
2. Mode Button
3. Menu - Button
4. Dome Light Switch
5. Display Panel Open Knob
6. Menu + Button
7. ^ Increase Button
8. v Reduce Button
9. IR Transmitter

1) Power ON/OFF Button ⏻

Press the button on the panel or on the remote control to turn on the power. Press again, to switch off power.

2) Mode Button

Select video input mode.

3) Menu Down Button

Press this button to activate control function OSD, and to select the desired control function under Menu.

4) Dome Light ON/OFF Switch

When the button is in ON/OFF position, pressing it will turn ON/OFF the dome light.

When the button is in DOOR position, it will activate the door to switch dome lights.

Note:

- *This function can be operational only when the red wire of the dome light is connected to the door sensor.*
- *The dome light will switch off after the car door is closed.*

5) Display Panel Open Button

When display is closed, push this button to release the LCD panel.

6) Menu Up Button

Press this button to activate control function OSD, and to select the desired control function under Menu.

7) ^ Increase Button

The button is for increasing/changing the feature values under Menu.

8) v Reduce Button

The button is for reducing/changing the feature values under Menu.

9) IR Transmitter

This IR Transmitter is for IR wireless headphone.

7. REMOTE CONTROL

Inside the vehicle, simply aim the IR Remote Control directly at the unit, and press any desired button for better effects.

Notes:

- Put the IR Remote Control from no further than 3 Meter on either side of the sensor.
- Direct sunlight or very bright light reduces sensitivity to the IR remote signal commands. Be sure the display is not located in direct sunlight.
- Obstruction between the remote sensor and remote control may disrupt reception.

Before using, please pull out the insulation sheet between the battery holder and the remote control.

8. BATTERY REPLACEMENT

If the remote control does not function correctly or the operating range shortened, please replace the old battery with a new one.

1. Follow the arrow 1 to slide it to the right toward the battery, at the same time to pull the battery holder away from the remote control as arrow 2 instructed.

2. Replace with a new battery.

Place a new lithium battery with the (+) side up.

3. Push the holder back.

Push back the holder until the locking sound is heard.

Notes:

- Dispose used battery properly.
- Do not misuse battery by shorting the positive “+” and negative “-” terminal or throw it into fire. Overheating may cause battery to explode and a fire hazard.
- Battery and battery holder can be a choking hazard. Keep the remote control unit away from young children.

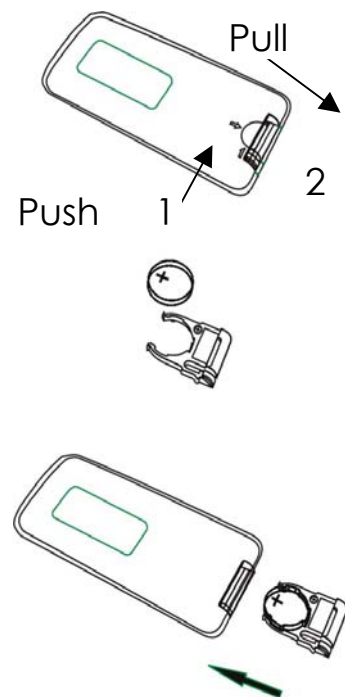

9. INSTALLATION INSTRUCTIONS

- To prevent short circuits, remove the key from the ignition and disconnect the terminal of battery.
- Make proper input and output cable connections for each unit.
- Connect the wire harness in the following order: ground wire, battery wire, ignition wire. Connect the wire harness connector with the display unit.
- Reconnect the terminal of the battery.

Notes for installation:

- Do remember to connect the red wire to the ACC of the ignition switch. Or the battery charge might be drained off prematurely.
- If the fuse is opened, first make sure that the cables have not caused a short circuit, and then replace the old fuse with a new one of the same ratings.
- Do not have unconnected cables or terminals touch the metal on the car or any other conducting material.
- To prevent short circuits, do not remove the caps from unused terminals or from the ends of the unconnected cables.
- After the display unit is installed, check and make sure the brake lights, blinkers, wiper, etc. on the vehicle are working properly.
- Insulate unconnected wires with vinyl tape or other similar material.

10. TROUBLESHOOTING

Problem	Cause	Solution
No picture when the display is turned on.	<ol style="list-style-type: none"> 1. Power wire is connected improperly or fuse blown. 2. System cable is not on right position. 	<ol style="list-style-type: none"> 1. Check the power wire and replace the fuse. 2. Check system cable or replace a new one.
Blue picture on the screen.	<ol style="list-style-type: none"> 1. Interfered by short-distanced strong interference. (E.g. high voltage wire, transformation station or aircraft etc...) 	The reception of signal will get better when moving away from Interference.
No function on the remote control (or operating distance is shortened).	<ol style="list-style-type: none"> 1. The battery of remote control has exhausted. 2. Remote control is defective. 	<ol style="list-style-type: none"> 1. Replace a new battery with same ratings. 2. Contact with dealer and replace a new remote control.
The picture on the screen is dark.	<ol style="list-style-type: none"> 1. The equipment locates at a low temperature area. 2. BRIGHTNESS is set too dark. 	<ol style="list-style-type: none"> 1. This is the characteristic of LCD display in low temperature, it will restore to normal brightness after starting the display for few minutes. 2. Check BRIGHTNESS adjustment.
No sound can be heard from the IR wireless headphone.	<ol style="list-style-type: none"> 1. Headphone is not switched on. 2. The battery in the headphone is low. 3. There is object blocking the transmitting module or beyond the effective receiving area. 	<ol style="list-style-type: none"> 1. Switch on the headphone. 2. Replace the battery. 3. Remove the blocking object or move back to the receiving area.

11. PICTURE ADJUSTMENTS

To adjust the picture, use the menu button to select the menu features you would like to adjust. Adjustment selections are as follows. The values of selected feature can be adjusted by pressing the “+” and “-” button on the remote control or “^” and “v” button on the panel.

Contrast
Brightness
Color
Tint
Wide Screen
LAC Enable
Reset

CONTRAST: Contrast adjustment
 BRIGHTNESS: Brightness setting
 COLOR: Color adjustment
 TINT: Tint adjustment
 WIDE SCREEN: Select display Mode
 LAC ENABLE: Yes
 RESET: Reset menu to default value

Display Mode

REMARK: system default is **WIDE**.

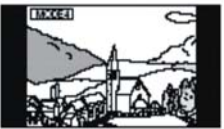
Display Mode	Display	Note
FULL		Normal images are expanded uniformly in the horizontal direction and are displayed over the entire screen.
NORMAL		Normal image (4:3)

12. LCD PANEL MAINTENANCE

- Wipe off any dust gently with a soft, dry cloth.
- The surface is easily scratched; do not rub it with hard objects.
- Do not use any chemical solvent, cleaning agent or corrosive detergent to clean away dirt on the surface of the screen.

13. SPECIFICATIONS

General Specifications

Power Source:	Car Battery (DC +10.5V ~ +16V)
Operating Voltage:	DC +12V
Mechanism:	Manual Open / Close
Display Angle:	Vertical Adjustable: Up/Down < 150°
Operating Current:	<1.2A(Dome Light Off)
Dome Light:	5W x2
Operating Temperature:	-20°C to +75°C
Storage Temperature:	-40°C to +85°C

14.WIRING/CONNECTIONS

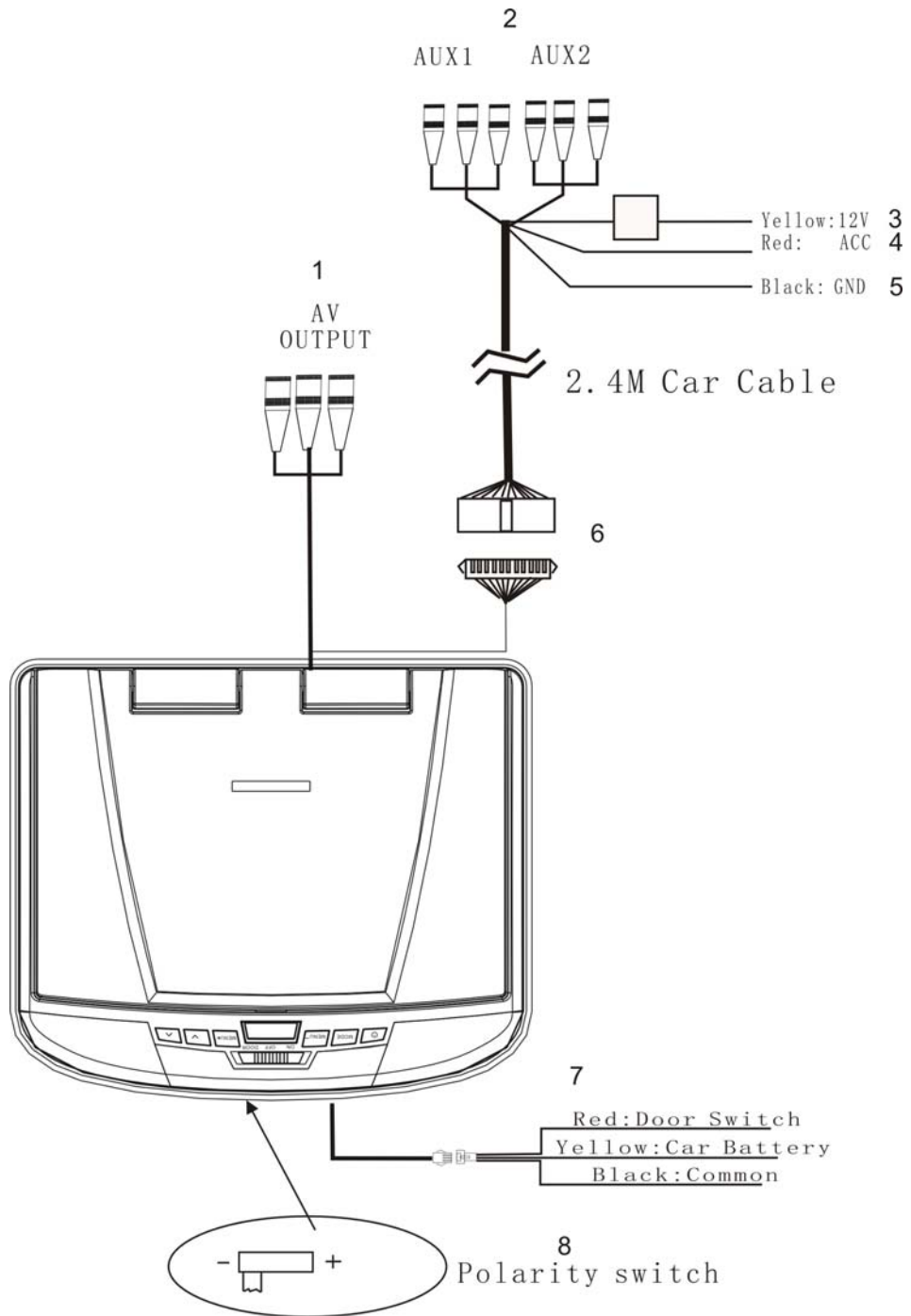

1.A/V Output

An auxiliary A/V output is provided to drive an external monitor. This signal mirrors what's being shown on the display. The volume function does not affect the Auxiliary A/V Output.

2.AUX A/V, Input 1(AUX A/V, Input 2)

3.Battery + lead (Yellow)

To connect the positive terminal of the car battery.

4.ACC Power Lead (Red)

To ACC power lead powered when engine key position is ACC.

5.Ground Lead (Black)

Connect the lead to a good chassis ground on the car. Make sure the connection is made to bare metal and is securely fastened using the sheet metal screw provided.

6. Connector

This is connected to the Overhead Monitor through the 2.4m, Mini-DIN Extension Cable.

7.Dome Light Wire

This wire connects the built-in Dome Light to the cable from the car's Dome Light Switch.

8.Polarity Switch

Please slide to “-” at the left position if your vehicle's power supply system is negative; Please slide to “+” at the right position if your vehicle's power supply system is positive.

Notes: 1.Please slide it to a side fully.

2.Do not slide this switch after installing the player. Otherwise, it'll be damage.

Positive Switched System

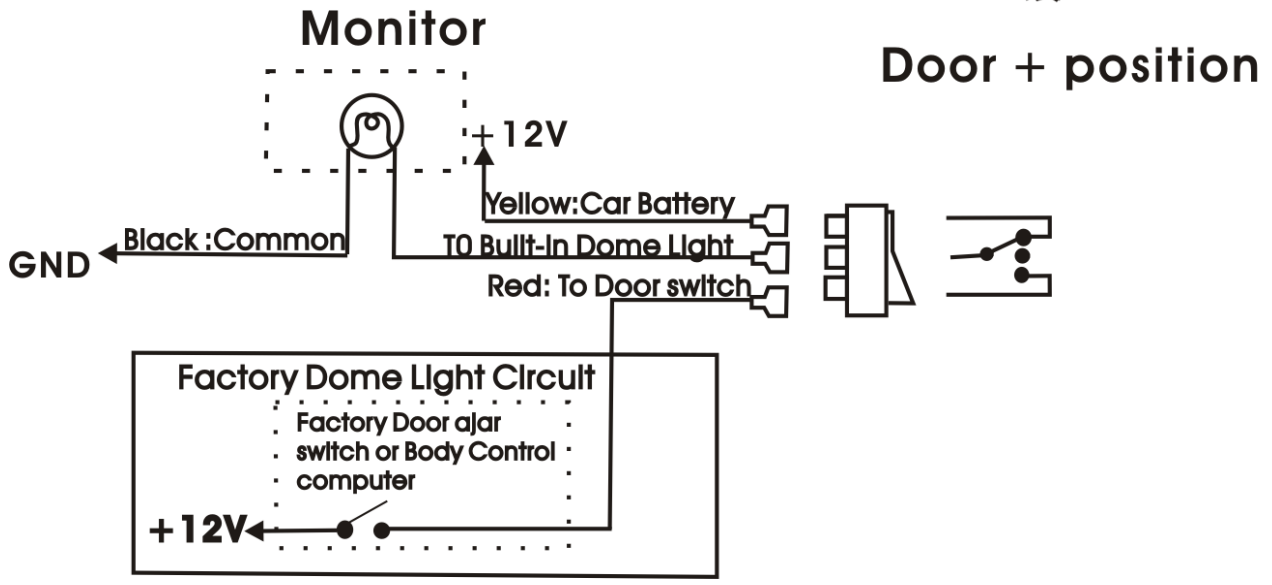

Negative Switched System

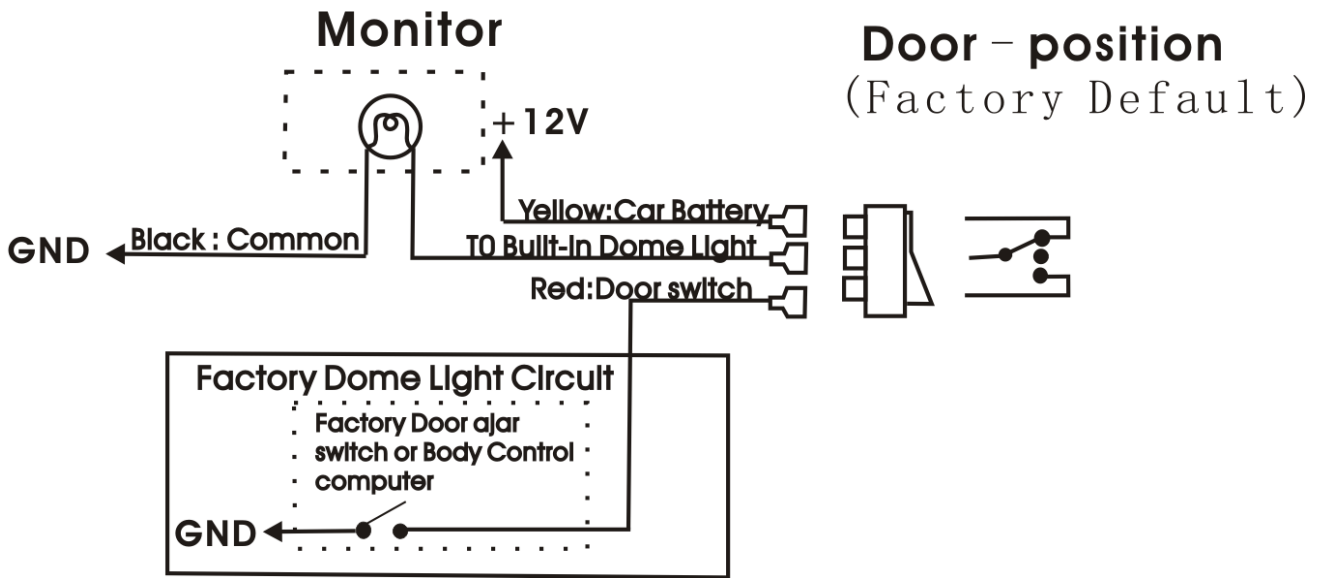

15. INSTALLATION STEPS

Step 1: Metal Mounting Plate Mounting

Screw the Metal Mounting Plate to the Car Roof by ST4.2x16 (See Figure 1). Please remember not to cover the opening of original dome light.

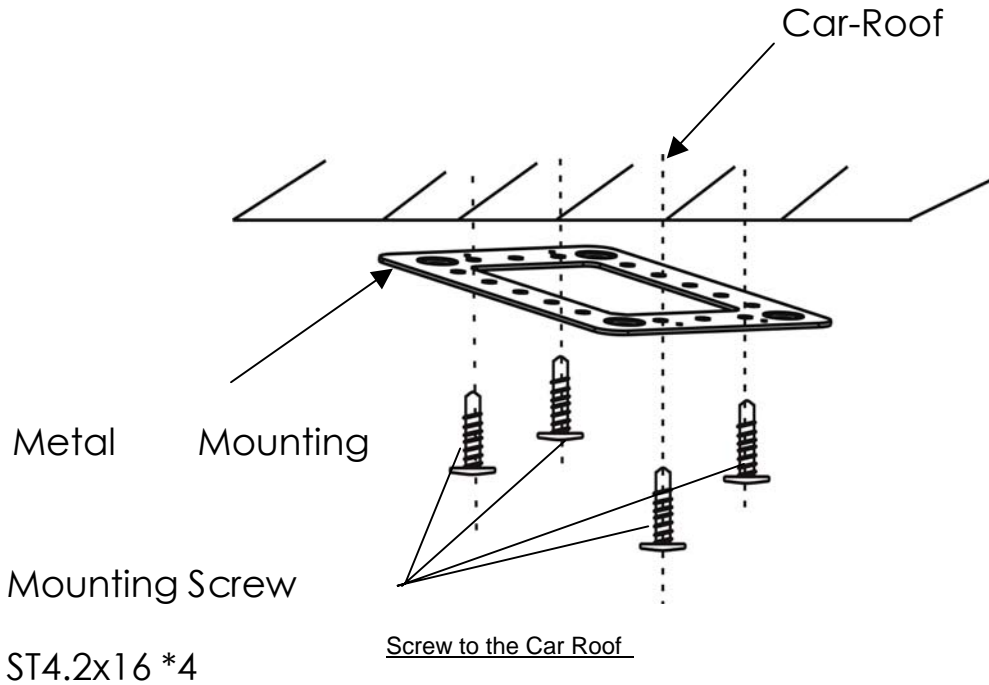

(Figure 1)

Step 2: Cable Routing

Pull out the AV Input/Output Cable, 3 Pin Dome Light Power Cable from the opening of original Dome Light.

Step 3: Cable Connection

Connect the extension cable of AV Input/Output Cable, 3Pin Dome Light Power Cable to the unit.

Step4: LCD Unit Mounting

Put the Rubber spacer on the bottom of the LCD Unit. And then press the open knob on this unit and open the LCD panel, then fix the unit to the mounting plate with four screws. And rip off the scraps which be conglutinated on adhesive foam. Later, use adhesive foam to cover the four screws (See Figure2).

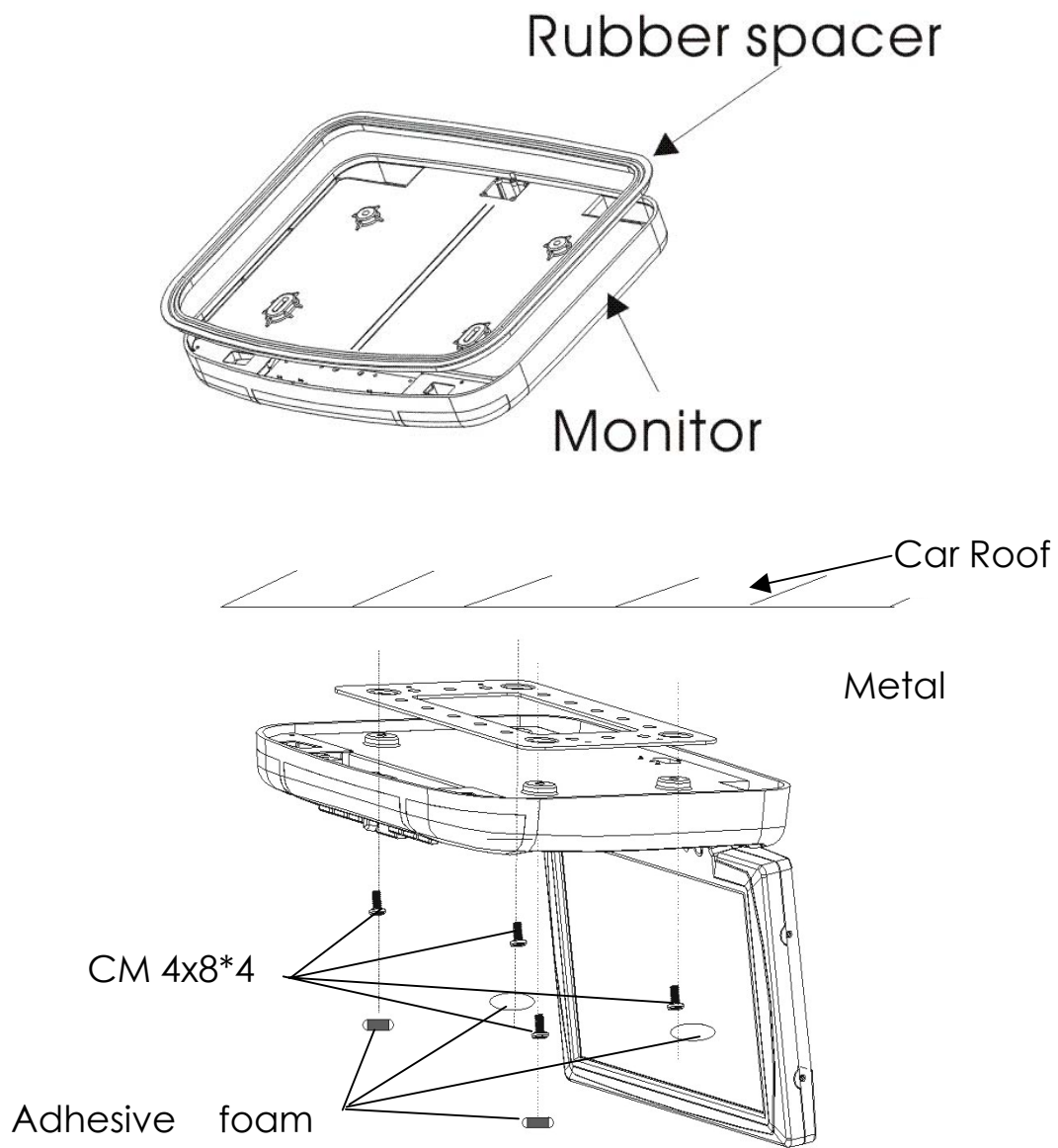

(Figure 2)

Step 5:

Please check and make sure this unit is installed properly before operation.